

Technical data sheet

380TA-230-20-S2/8Fx Spring return servomotor for fire and smoke protection

Description

Spring return servomotor including external thermal tripping device TA-72 (72°C) for adjusting fire and smoke protection dampers in HVAC installations

- Running time motor 75 s / 90°
- Running time spring 20 s / 90°
- Torque motor 20 Nm
- Torque spring 20 Nm
- Nominal voltage 230 VAC/DC
- Control 2-point
- Auxiliary switch 2x fixed, not adjustable
- Shaft coupling form fit 8 mm (8F 8)
form fit 10 mm (8F10)
form fit 12 mm (8F12)

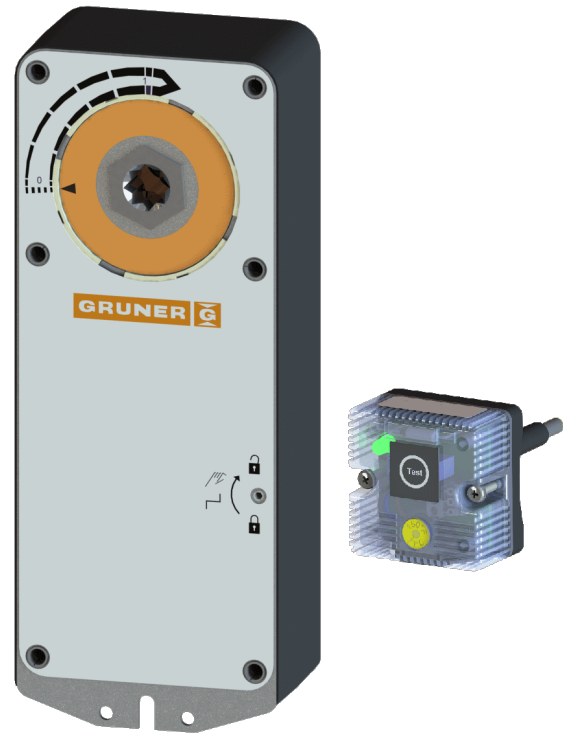

Technical data

Electrical data	Nominal voltage	230 VAC/DC, 50/60 Hz
	Voltage range	85...265 VAC/DC
	Power consumption motor (motion)	9,0 W
	Power consumption standby (end position)	2,5 W
	Wire sizing	14,0 VA
	Wire sizing note	
	Control	2-point
	Feedback signal	-
	Auxiliary switch	2 x SPDT (AgAu)
	Contact load	1 mA...5 (2,5) A, 5...250 VDC
	Switching point	5° / 80°
	Connection motor	cable 1000 mm, 2 x 0,75 mm ² (halogen free)
	Connection auxiliary switch	cable 1000 mm, 6 x 0,75 mm ² (halogen free)
	Connection GUAC	-
Functional data	Torque motor	20 Nm

Technical data

Functional data	Torque spring	20 Nm
	Synchronized speed	±5%
	Direction of rotation	selected by mounting
	Manual override	manual operation
	Angle of rotation	-5°...max. +90°
	Running time motor	75 s / 90°
	Running time spring	20 s / 90°
	Sound power level motor	< 45 dB(A)
	Sound power level spring	< 65 dB(A)
	Shaft coupling	form fit 8 mm (8F 8) form fit 10 mm (8F10) form fit 12 mm (8F12)
	Position indication	mechanical with pointer
	Service life	> 60 000 cycles (-5°...+90°...-5°)
	Thermal tripping device	2 x acc. EN 60691
	Temperature TF1	+72°C (inside-duct)
	Temperature TF2	+71°C (outside-duct)
	Safety	Protection class
Degree of protection		IP 54
EMC		CE (2004/108/EG)
LVD		CE (2006/95/EG)
RoHS		CE (2011/65/EU)
Mode of operation		Typ 1 (EN 60730-1)
Rated impulse voltage supply / control		4 kV (EN 60730-1)
Control pollution degree		3 (EN 60730-1)
Ambient temperature normal operation		-30°C...+50°C
Ambient temperature safety operation		> +75°C
Storage temperature		-30°C...+50°C
Ambient humidity		5...95% r.H., non condensing (EN 60730-1)
Maintenance	maintenance free	
Dimensions / Weight	Dimensions	250 x 98 x 59 mm
	Weight	2700 g

Functionality / Properties

Operating mode

Connect power supply to wire 1+2, the servomotor drives to position 1 while the pre-tensioned spring is wound up the same time. If the power supply is interrupted, the servomotor drives back to position 0 by spring power. The servomotor is still maintaining the minimum torque at the damper spindle.

The servomotor is overload-proof, requires no limit switches and automatically stops when the end stop is reached.

Operating mode TAE

The external thermoelectric tripping device consists of two thermal fuses TF1 and TF2. If the ambient temperature $+71^{\circ}\text{C}$ or the inside-duct temperature $+72^{\circ}\text{C}$ exceeds, the tripping device is tripped the temperature fuse and the power supply will be irreversible interrupted. The tripping device TAE is equipped with a test switch and a LED.

The LED is green if the servomotor is powered on and the fuses have not tripped.

The LED is red if the test switch is pressed.

Direct mounting

Simple direct mounting on the damper shaft with a form fit, protection against rotating with enclosed anti-rotation lock or rather at intended attachment points.

Manual override

The servomotor can only be operated manually while the power supply is off. The supplied lever is used to open and lock the damper position. The lock stays until the power supply is switched on again.

Signaling

The two integrated auxiliary switches are activated at the fixed switching positions ($> 5^{\circ}$ and $> 80^{\circ}$). The damper position can be checked by the mechanical pointer.

Connector / Security Note

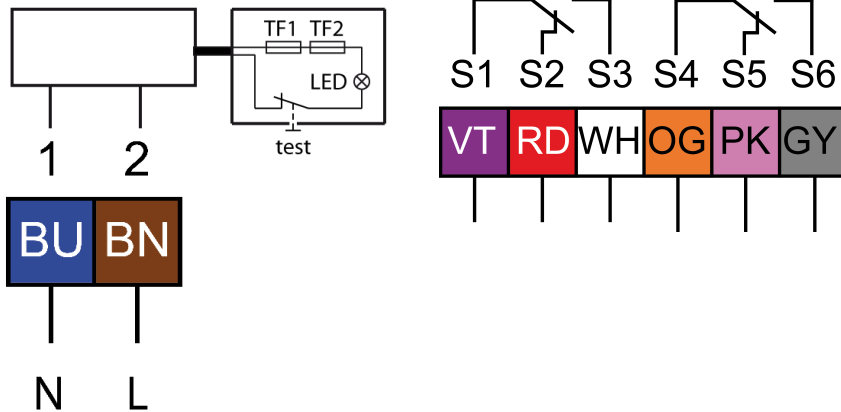

Safety remarks

- Caution: power supply voltage!
- The device is not allowed to be used outside the specified field of application, especially in airplanes.
- It may only be installed by suitably trained personnel. Any legal regulations or regulations issued by authorities must be observed during assembly.
- The device may only be opened at the manufacturer's site.
- The device is not allowed to be disposed of as household refuse. All locally valid regulations and requirements must be observed.
- When calculating the required torque, the specifications supplied by the damper manufacturer's (cross-section, design, installation site), and the air flow conditions must be observed.
- The device is adapted and mounted to the fire and smoke damper by the damper manufacturer. For this reason, the device is only supplied direct to safety damper manufacturer. the manufacturer then bears full responsibility for the proper functioning of the damper.

Technical Drawing

