

Technical data sheet

Relay 725

Description

Polarized latching relay for 100 A

Using the H-armature principle the polarised latching relays are noted for their high resistance to shocks and vibrations. They are always in a defined switching position and therefore there is no loss of information in case of power failure. The advantage of polarised latching relays is the pulse driven operation of some milliseconds, coil heating can be neglected.

The relays are designed and manufactured in accordance to international standards of IEC 61810 part 1 as well as they meet the UC2 requirements for Supply Control Switches as of IEC 62052 part 31 and IEC 62055 part 31.

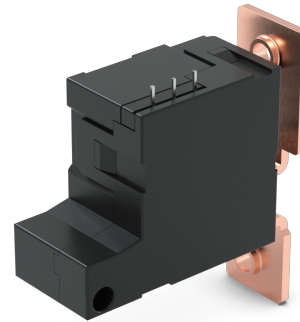

Technical data

Coil data	Rated voltage	6 – 48 VDC
	Rated power	5.5 W
	Operating power to set	3.5 W
	Pulse to set	20 ms
	Action time	< 15 ms
Contact data	Max. contact arrangement	1 NO
	Contact material	AgSnO ₂
	Max. switching power	25000 VA
	Max. switching voltage	440 VAC
	Rated switching current	100 A
	Mechanical life	10 ⁶
Insulation	Creepage and clearance distance coil - contact	8.0 mm
	Test voltage coil - contact	4000 V eff.
	Test voltage contact- contact	V eff.
	Test voltage open contact	1000 V eff.
	Dielectric strength coil - contact	12 kV / 1,2 / 50 µs

Technical data

General data	Ambient temperature	-40 ... +85 °C
	Weight	70 g
	Conform to	VDE, UL, CSA, SEV, SEMKO

Standard windings

Standard winding No.	Nominal coil voltage (VDC)	Operating voltage of the coil U1 - U2 (VDC)	Coil resistance (Ohm)	Tolerance (± %)
6R5	6	4,8 - 7,8	2 x 6.5	10
025	12	9,6 - 15,6	2 x 25	10
105	24	19,2 - 31,2	2 x 105	10
430	48	38,4 - 62,4	2 x 430	10

Contact position

Terminal-grid

The relay can also be used with a single winding (lower operating power to set) if the middle pin of coil is not used. Furthermore, the magnet's polarization can also be adjusted to meet the customer's specific drive circuit requirements.

Identification

Identification code		725	D	-	R	1A	-	B	025
Type	725								
Terminal configuration	D = see dim. drawing DR = see dim. drawing F = see dim. drawing								
Contact material	R = AgSnO ₂								
Contact arrangement	1A = 1 normally open								
Terminal-grid	B								
Winding No.	see coil table								

Advice for soldering:

The relay is dust-protected. Take care to avoid that flux medium and lead-tin resp. their evaporations enter into the relay, i.e. the printed circuit board must not be flooded.

Extended storage could impact solderability due to increased oxidation on the terminals.

Shunt:

The Shunt is used to measure the energy consumed and, as it is integrated in the relay, can be utilised for load shedding in “Energy Management”. Two connectors are located on the terminal close to the shunt and only carry the current sensor signal. A third connector is the reference signal for the electronics and is located on the supply side of the terminal to avoid RF sensitivity.

The power terminals can be modified according to customer specification.

Technical drawing

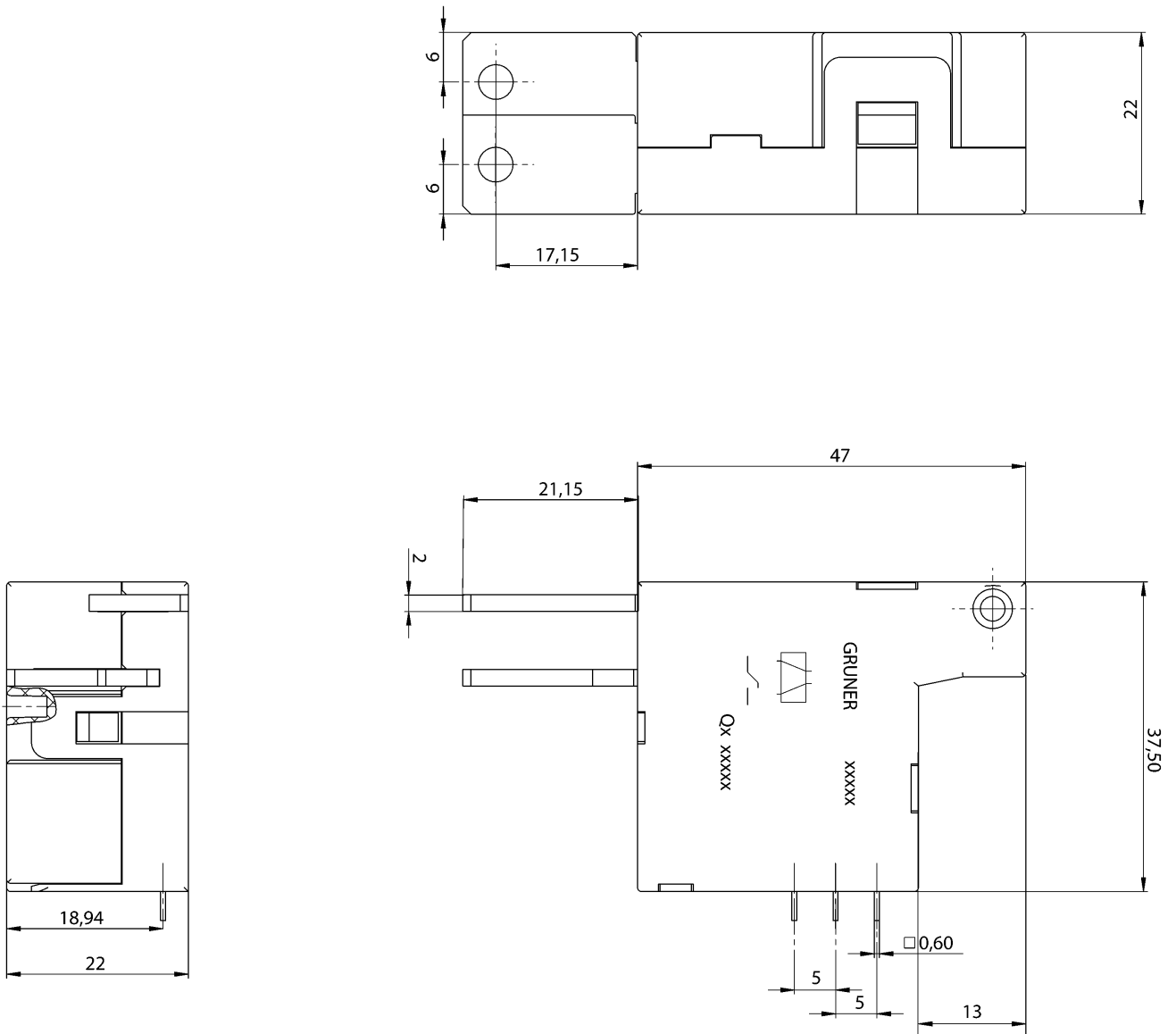

725 C

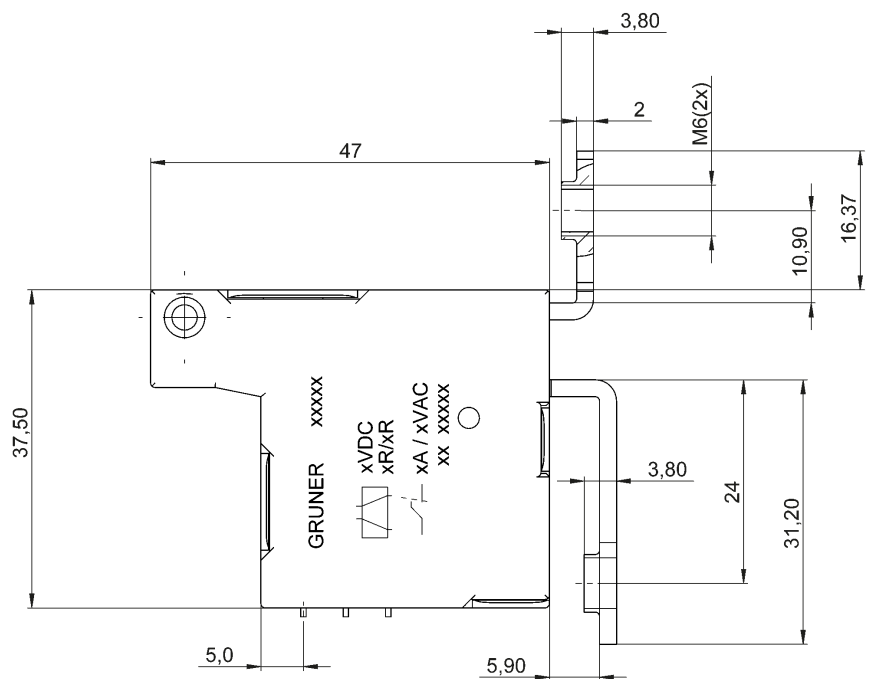
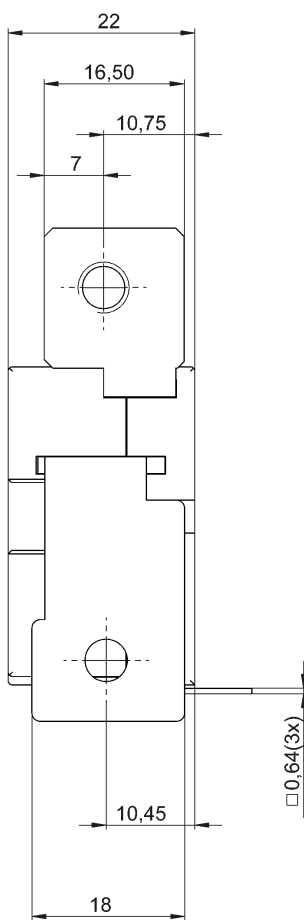
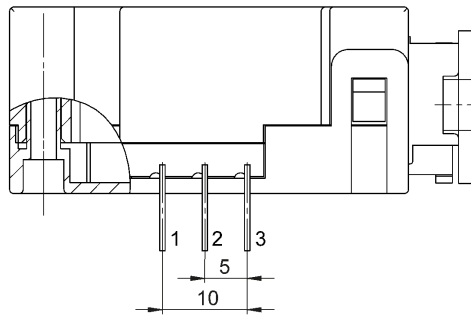

725 D

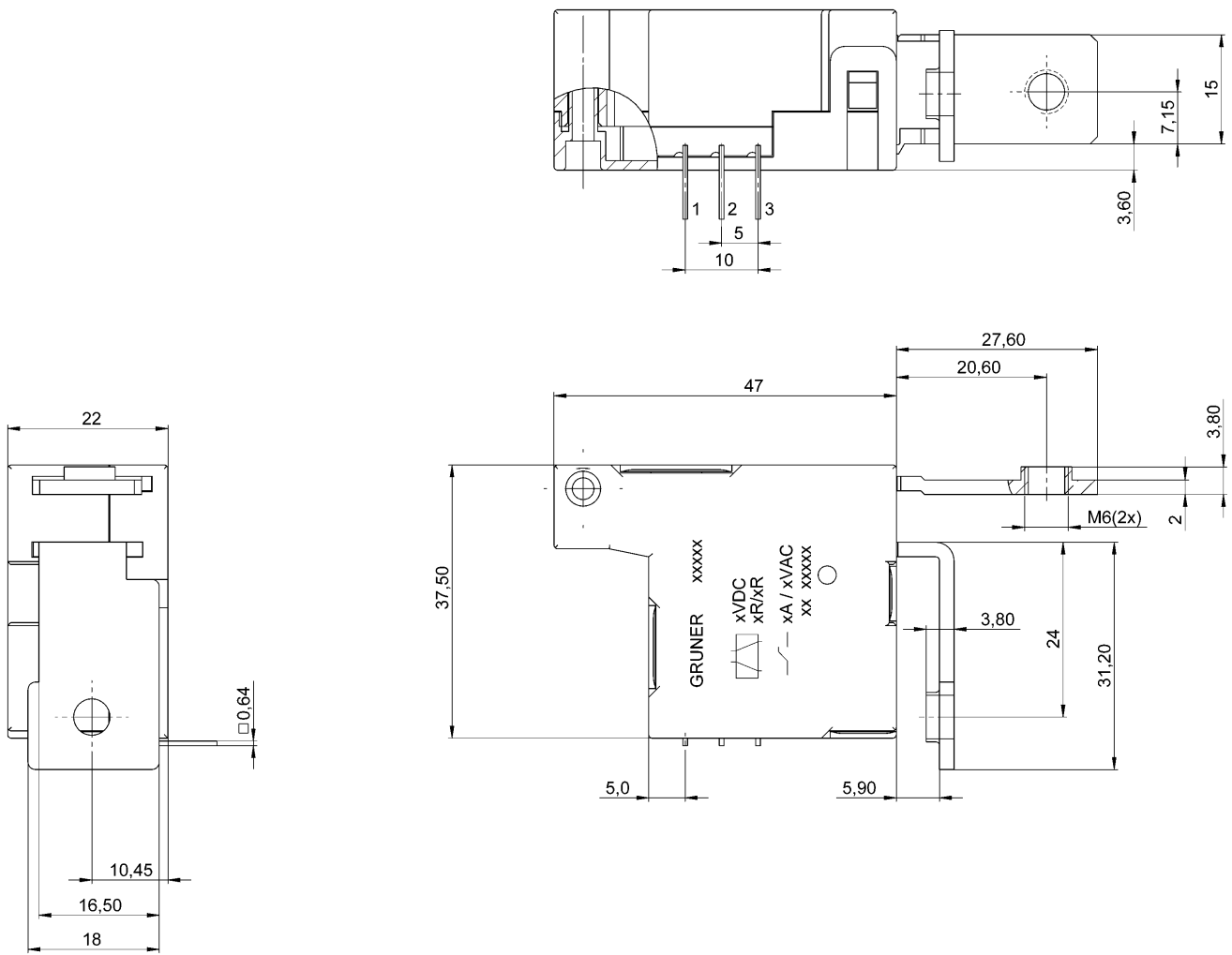

725 F

